

How to measure for window and door trim for 2" thick x 4" wide trim.

The lengths we stock are 8', 10', and 12' (we can also make 16' for larger windows)

You can miter your trim at 45 degrees or butt and pass by putting on the bottom first, and then the sides capping the bottom piece, and then the top capping the sides (see drawing).

Usually the windows width is different than the height so I measure the top and side and round up to the nearest 8', 10', or 12' length.

Example: Measure the width of the outside edge of the windows and add 8" to cap the side trim, then measure the height and add 4" for capping the bottom trim. Add these two and round up. You will need two for each window this size.

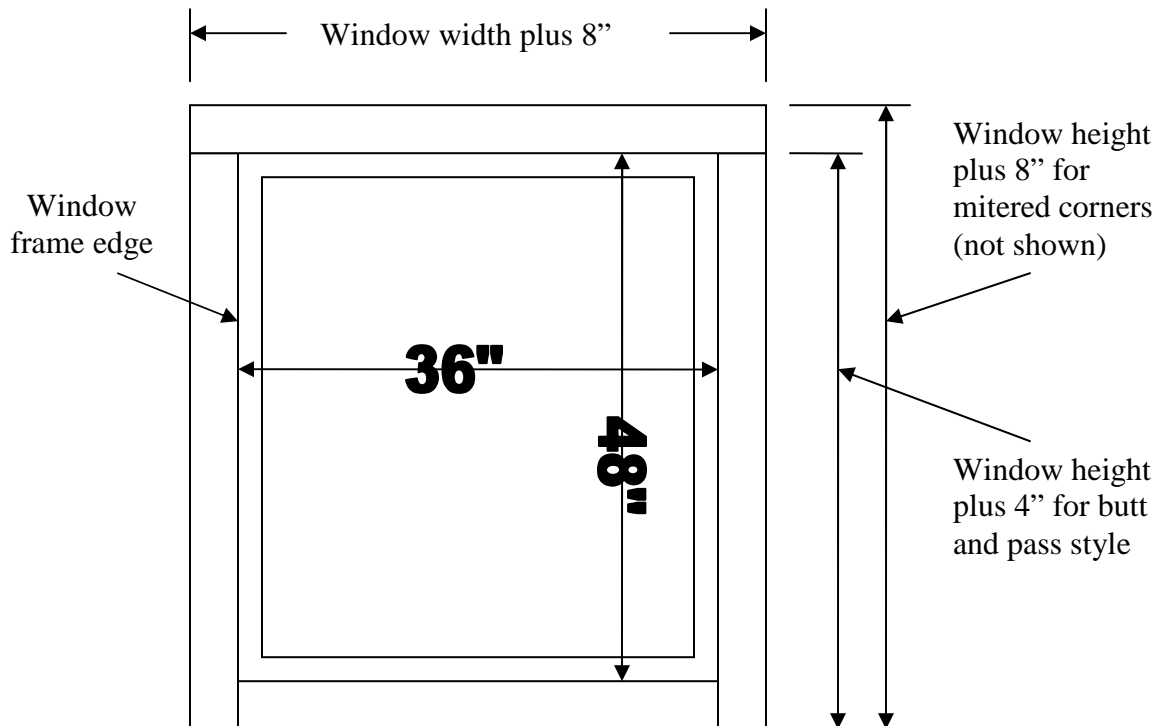

Butt and pass trim: $36 + 8 + 48 + 4 = 96"$ (8') you would need 2 - 8' pieces.

Mitered trim: $36 + 8 + 48 + 8 = 100"$ (8' 4") you would need 2 - 10' pieces.

You may want to draw out all your windows and doors on some note paper and measure them so it is easier to see what all the different sizes will be. You will then have a map for when the trim arrives. Note: It is better to have a little extra than to be short a piece.

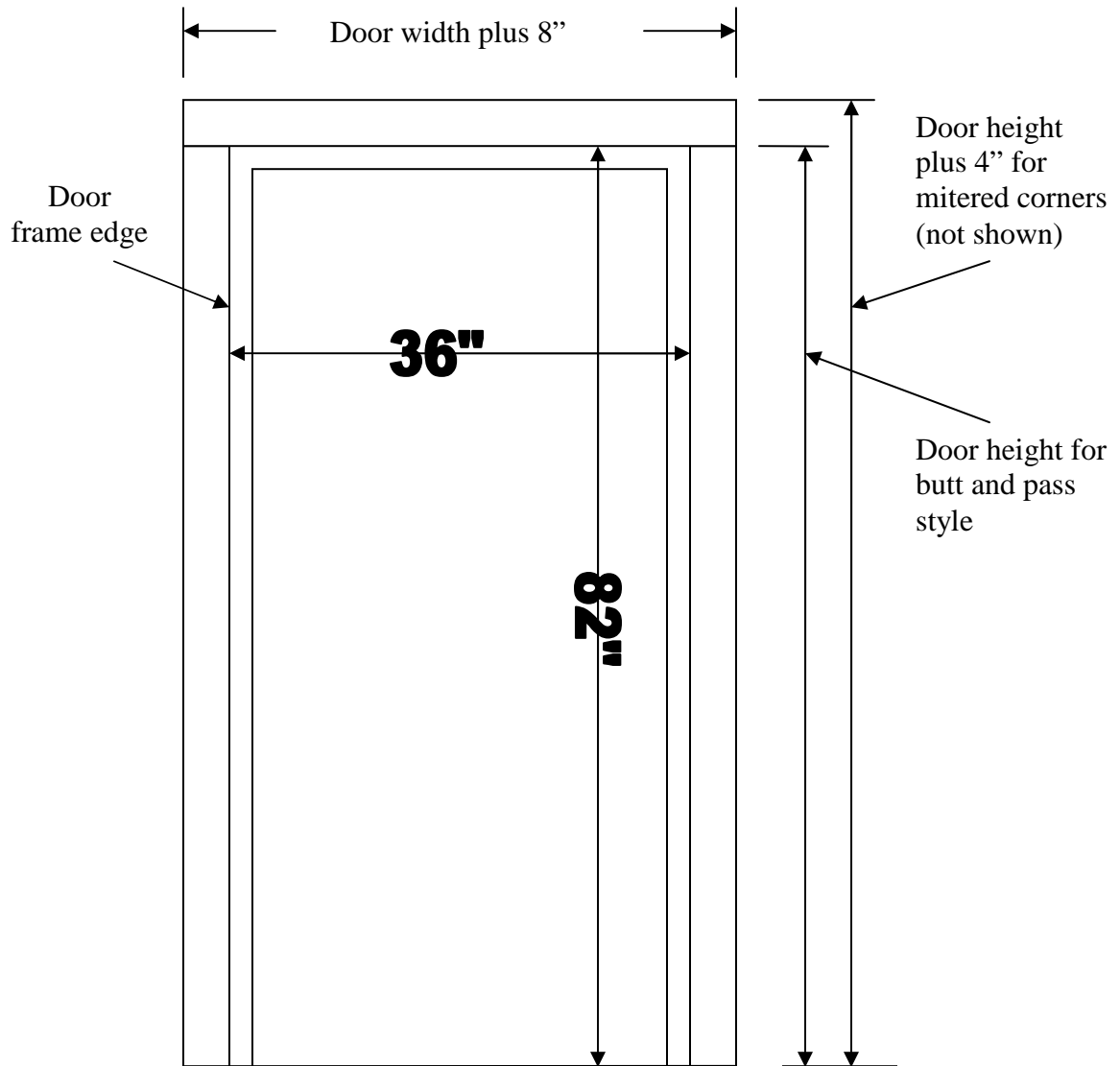

Examples:

For one 36" door you would need 1 – 8' and 1 – 12' pieces

For Two 36" doors you would need 5 – 8' pieces

For a 6' wide patio door you would need 3 – 8' pieces

Please call if you need help. Jeff Glaza, Classic Log Homes, 715-887-2550